

CLASSIC® 830 In-Line Threaded



Flow, Level, Interface & Temperature Switch & Transmitter

- Threaded Process Connections - 3/4" FNPT
- For use inline sizes of 3/4" or less and/or applications with very low flow.
- Exotic Alloys and Remote Mounted Electronics Available
- Digital Microprocessor Technology - Settings configurable by user for Flow, Level, Interface & Temperature Sensing
- No Jumpers - All Configurable Options are stored in Non-Volatile Memory
- CSA Flameproof Class I, Div. 1, Groups B, C & D

Display Panel & Intelligent User Interface

The **KAYDEN CLASSIC 800** Series Electronics Module is designed for quick and easy setup.

All **CLASSIC 800** models, regardless of the type of sensor, use the same Electronics Module.

Display Panel Indicators:

- Relay 1 & 2 Set Point 1 & 2
- Fault Alarm
- Run Mode
- Start-up Bypass Timer (for pump control)
- LED Bar Graph for Flow Rate, Level or Interface Indication

- Universal Power 12-24 VDC & 115-230 VAC standard
- Two SPDT Relays - independently adjustable
- 4-20 mA Analog Output
- "Smart Heater" function for power economy and increased heater life
- Start-up Bypass Timer (for pump control)

Configuration Mode Features:

- Adjustable Sensitivity
- Zero & Span Adjustment
- Modbus Addressable

Electronics Modules Feature:

- Easy setup; no jumpers or trim pots
- Continuous Self-test Diagnostics with Fault Indicator
- Temperature Compensation

Applications:

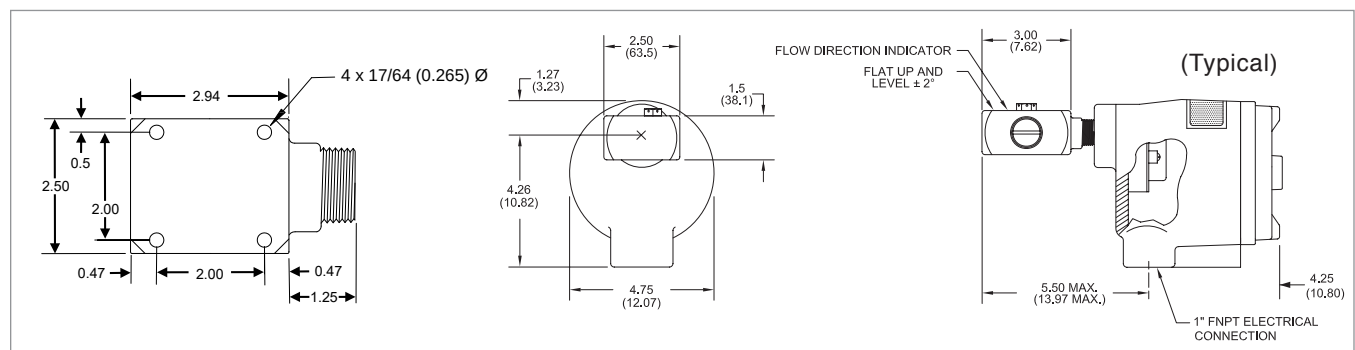
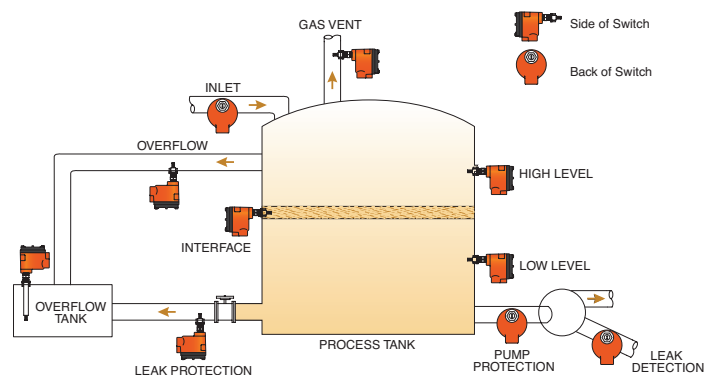

830	CODE	Sensor Type													
	R	-55°C to +200°C (-58°F to +392°F) Continuous Service													
	CODE	Sensor Material													
	A3	316/316L Stainless Steel c/w Nickel Braze													
	CODE	Process Connection - FNPT													
	D	3/4"													
	CODE	Sensor Assembly Body Length													
	0035	3.5" (8.8 cm)													
	CODE	Bleed Port													
	A	Standard													
	CODE	Sensor Mounting Orientation													
	H	Horizontal Pipe													
	V	Vertical Pipe													
	CODE	Injection Tubes 3/4" MNPT x 1/4" FNPT													
	0	Not Required													
	1	Type 1; .180" Bore; 316/316L Stainless Steel													
	2	Type 2; .086" Bore; 316/316L Stainless Steel													
	CODE	Mounting Bracket Kit													
	A	Not Required													
	B	90° Angle Bracket with hardware for wall/stand mounting													
	CODE	Power													
	C	12-24 VDC and 115-230 VAC, 50 to 60 Hz													
		Electronics													
		Microprocessor Controlled with User Interface. Two SPDT fully sealed relay contacts. Modbus via RS-485. 4-20 mA current loop.													
	CODE	Local Enclosure													
	1	Flameproof - Aluminum													
		CODE	Cover - For Local Enclosure / Sensor Enclosure												
		B	Blind Cover - Flameproof												
		G	Glass Lens Cover - Flameproof												
		CODE	Remote Electronics Enclosure & Cover												
		0A	Not Required												
		1G	Glass Lens Cover - Flameproof												
		CODE	Agency Approvals												
		1	CSA _{us} (UL Standards)												
		CODE	Language												
		E	English												
830	R	A3	D	0035	A	H	1	A	C		1	B	0A	1	E



Flow, Level & Temperature Switch & Transmitter

© Kayden Instruments All rights reserved. Contents subject to change without notice. Please refer to kayden.com for current specifications and configurations.

Model Number Legend
DOC#: ML-830-006

ML-830-006-[004]

CLASSIC® 800 Specifications

Applications

- Flow, Level, Interface & Temperature

Process Connections

- 1/2", 3/4", 1", 1-1/4", 1-1/2" & 2" MNPT
- 3/4" FNPT & Flanged InLine
- Threaded (1" MNPT) & Flanged Retractable Packing Glands

Insertion 'U' Lengths

- **Imperial**
1.2", 2", 3", 4", 6", 9", 12" & 18" standard
- **Metric**
3, 5, 7.5, 10, 15, 23, 30 & 45 cm standard
- **Custom Lengths**
Available in 1/2" or 1 cm increments
Min. 2.5" - Max. 120" (6.0 - 305 cm) model dependant

Wetted Materials

- 316/316L Stainless Steel - standard
- Titanium Gr. 2, Hastelloy C-276
- 316/316L Stainless Steel c/w Nickel Braze (830 & 832 InLine Models)

Enclosure Material

- Copper-free Aluminum (does not exceed 0.4% copper)
- Powder Coated Polyester TGIC (polyester triglycidyl isocyanurate)
- NEMA 4, 4X, 6P; IP65/67
- 1" FNPT Conduit Connection
- Buna O-Ring on Cover

Temperature Range – Continuous Service

- **Sensors**
-55°C to +200°C (-58°F to +392°F)
(Models 814 & 816: -55°C to +160°C [-58°F to +320°F])
- **Electronics**
-55°C to +65°C (-67°F to +149°F)

Note: For temperatures above +65°C (+149°F) electronics must be remotely mounted. Refer to Electronics Location Considerations Page 10.

- **Storage**
Product should be stored in a clean and dry environment between -30° and +60° C (-34.5° and 140° F)

Operating Pressure - Sensor

Threaded Style

- Maximum Working Pressure 24 MPa (3500 psig) dependent on model and material of construction

Flanged Style

- Maximum Working Pressure per flange rating

Switch Point Range

(Insertion Style - 1/2" to 2" MNPT, Flanged)

- **Water-based Liquids**
0.01 to 3.0 ft./sec. (0.003 to 0.9 meters/sec.)
- **Hydrocarbon-based Liquids**
0.01 to 5.0 ft./sec. (0.003 to 1.5 meters/sec.)
- **Gases**
0.25 to 254 sfps (0.076 to 77 smps)
Standard conditions: 21°C (70°F) at 14.7 psi (1 atm)

Switch Point Range

(InLine Style)

- **Water-based Liquids**
0.015 to 50 cc/sec.
- **Hydrocarbon-based Liquids**
0.033 to 110 cc/sec.
- **Gases**
0.6 to 20,000 cc/sec.
Standard conditions: 21°C (70°F) at 14.7 psi (1 atm)

Accuracy

- **Flow Service**
±1% set point velocity over operating range of ±28°C (±50°F)
- **Level Service**
±0.25 inches (±0.64 cm)
- **Repeatability**
±0.5% Thermal Signal
- **Hysteresis (Dead Band)**
±1% Thermal Signal
- **Temperature**
±1° C or ±2% of full-scale range, whichever is greater.

Response Time

- Approximately 0.5 to 30 seconds

Remote Electronics Option

- Maximum recommended cable length - 200 feet (60 m)
- Cable type - 24 AWG minimum - twisted pairs

Heater Power

- Field adjustable to optimize performance

Input Power

- Universal Power standard 12-24 VDC and 115-230 VAC, 50-60 Hz
- Consumption Maximum 6.0 Watts
- DC input has reverse polarity protection
- AC & DC inputs have TVS diodes to protect against transient voltages (390 VAC, 39 VDC)
- Internal 1A self-resettable non-user-replaceable fuse

Outputs

- 4-20 mA current loop (with reverse voltage protection)
- Two (2) independent SPDT fully sealed relay contacts rated @ 4 amps resistive 230 VAC or 30 VDC Max.; individually adjustable

Start-Up Bypass Timer

- Adjustable: 0 to 100 seconds

Communications

- Modbus RTU via RS-485

Additional Features (Configure Using Kayden RCM Software or Modbus)

- Display Panel Lock-Out
- Set Points Configuration¹
- Relay Actuation Delay Timer
 - Independently configurable for both On and Off, increasing or decreasing
 - Adjustable from 0 - 5000 seconds
- Start-up Bypass Timer¹
 - Adjustable from 0 - 100 seconds
- Relay Mode Configuration¹
 - Energized above or below set point
- Relay Temperature Switch Configuration
- Heater Power setting¹

- Lower and Upper Range Values (LRV & URV) settings¹
- Analog (4-20 mA) output configuration¹
- View and Print Graphing (Trend) function
- Configuring settings; write to device, save to file and print
- Fault Event Log

Diagnostics

- Primary watchdog circuit monitors microprocessor parameter for anomalies
- Secondary watchdog circuit monitors microprocessor health
- Heater monitored for out-of-range conditions
- Fault Mode de-energizes relay(s) and halts power to the heater

Agency Approvals

- **CSA**
Class I, Div. 1, Groups B, C and D; Ex d IIB + H2; AEx d IIB+H2 (Class I, Zone 1, Group IIB + H2,) T3; Enclosure Type 4 / IP55
- **Single Seal Approval**
Per ANSI/ISA 12.27.01-2003
- **CRN** - Canadian Registration Number
 - CLASSIC 810: 0F22124.2C
 - CLASSIC 812:
 - 1" & 1-1/2": 0F13787.2C
 - 2" to 10": 0F13773.2C



Note: Visit kayden.com for CRN specifics.

Factory Certifications

- Factory tested to NEMA 4, 4X, 6P; IP65/67. Contact Technical Support for reports.

Weights and Dimensions

- 810 Threaded 2" U length - 7 lbs (3.18 kg)
- Carton Size - 15" x 5" x 6" (38 cm x 13 cm x 15 cm)
- Other models/sizes - consult Kayden

Warranty

- One (1) Year from shipment date from factory (see Terms & Conditions on kayden.com for details)

Note: ¹ Also configurable from Display Panel